

No. 646,390.

Patented Mar. 27, 1900.

L. T. PARSONS.
TOOL HOLDER.

(Application filed Jan. 5, 1900.)

(No Model.)

Fig. 1.

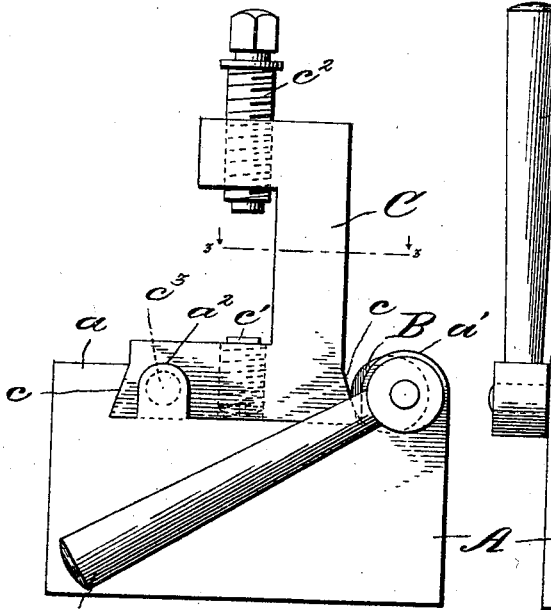

Fig. 2.

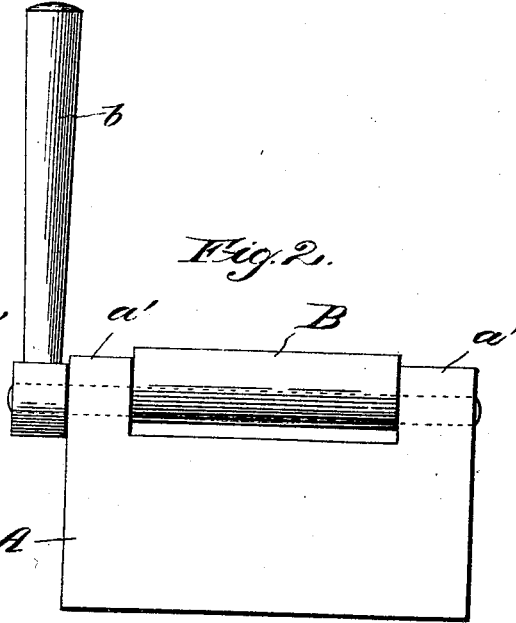

Fig. 3.

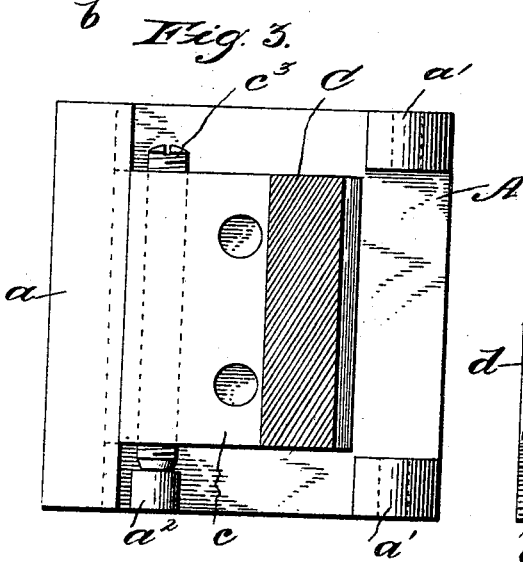
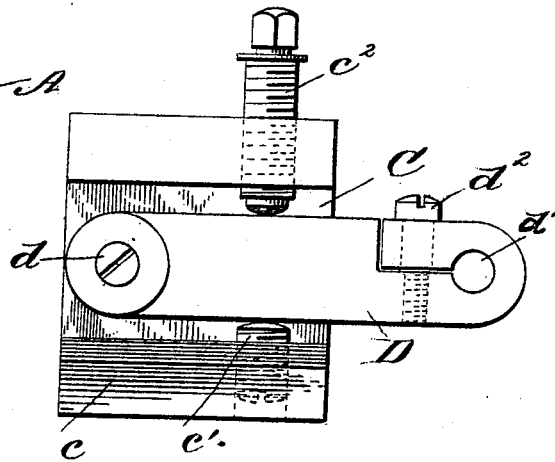

Fig. 4.



Witnesses
Alfred [Signature]
Robert [Signature]

Inventor:
L. T. Parsons
By *[Signature]*
Attorney

UNITED STATES PATENT OFFICE.

LUTHER T. PARSONS, OF NEW YORK, N. Y., ASSIGNOR TO WARREN SEYMOUR BELDING, OF SAME PLACE.

TOOL-HOLDER.

SPECIFICATION forming part of Letters Patent No. 646,390, dated March 27, 1900.

Application filed January 5, 1900. Serial No. 471. (No model.)

To all whom it may concern:

Be it known that I, LUTHER T. PARSONS, a citizen of the United States, and a resident of New York, (Prince's Bay,) in the county of Richmond and State of New York, have invented certain new and useful Improvements in Tool-Holders, of which the following is a specification.

My invention relates to devices for use in metal-working machines for securing and holding a tool in fixed relation to the work and commonly known as "tool-holders."

The holder which I have invented, while applicable to a variety of metal-working machines—such as planers, shapers, &c.—in which the work has a reciprocating motion relative to the tool, is peculiarly adapted and intended for use in connection with metal lathes in which the work rotates with respect to the tool.

In shaping metal, and especially in the operations of turning and boring, a number of tools of different character are frequently used successively on the same piece of work before it is finally brought to the desired shape or configuration. The removal of each of the several tools in succession and the insertion of others to bring the work to the desired shape and dimensions causes some loss of time, and where the work done on the machine is being duplicated to furnish a number of pieces identical in form and size the item of time is an important and expensive factor in the cost of production.

The tool-holder which I have invented is intended to obviate the difficulty noted above and enable the attendant to change the tools easily and expeditiously without the necessity of resetting each of the several tools after they have once been adjusted to the first or pattern piece.

My tool-holder comprises, generally speaking, a tool-post in which the tool may be secured in any desired position of adjustment, a tool-post support or block to which the tool-post is secured, and means whereby a tool-post and its tool may be securely locked to the support and at the same time be readily and quickly removed by the workman when it is necessary or desirable to substitute a

cutting or boring tool of different character from the one in use.

I shall now describe in detail the tool-holder outlined above, having reference to the drawings accompanying and forming a part of this specification, and in the claims appended hereto set forth the novel features of my invention.

In the drawings, in which the same letters refer to the same parts throughout the several views, Figure 1 is an end view of a tool-holder embodying my invention. Fig. 2 is a side view of the holder, showing the tool-post locking or clamping means. Fig. 3 is a plan view of the holder shown in Fig. 1, the upper part of the tool-post being broken away on the line 3 3, Fig. 1, for the sake of clearness of illustration. Fig. 4 is a view of the tool-post looking from the left in Fig. 1, showing the said post adapted for holding drilling or boring tools.

A indicates the tool-post support or block, which is secured to some part of the machine (usually the carriage) in any suitable or desirable manner. Said block A is provided at one side with an undercut abutment or rib *a*, preferably formed integral therewith, as shown. At the other side of said block A a cam-roll B is mounted, said cam B having its bearings in lugs *a' a'* and being provided with an operating-handle *b*, by which it may be thrown to and from its clamping or locking position. Said block or support A is provided also with a lug *a²*, the purpose of which will presently appear. Seated on said block or support A is the tool-post C, which, as shown, has an angular or dovetailed base *c*, so as to engage the undercut rib or abutment *a* on one side of block A, the result of this construction being that when the cam B is thrown to its locking or clamping position the tool-post C is securely clamped against the rib *a*, as clearly shown in Fig. 1. Said tool-post C has a slight lateral movement on the block or support A, so that it will slide transversely of the block when the cam B is forced against it and engage the undercut abutment *a* snugly. When said cam B is thrown off or to its unlocked position, the tool-post C by a slight lateral movement may be disengaged

from the undercut abutment *a* and be readily removed.

In order that the tool may be adjusted to different heights in the tool-post C, I provide adjusting-screws *c' c'*, which are tapped in holes in the base *c* of the tool-post, and by raising or lowering the said screws *c' c'* the position of the tool may be regulated, a set-screw *c²* being provided for securing the tool in the tool-post in its adjusted position.

In order to secure the necessary adjustment of the tool-post C lengthwise the tool-post support or block A, I provide said tool-post with an adjusting-screw *c³*, tapped in the base *c* and bearing against the lug *a²* on the block A when the tool-post C is in position, so as to hold the tool-post C in any desired position of adjustment lengthwise the block A.

From the foregoing description it will be obvious that the tool-post may be readily and quickly inserted or removed from the block or support, that its position lengthwise said holder may be accurately adjusted, and that the tool to be used may be readily adjusted to different heights in the said tool-post.

It will be understood that in practice and where a piece of metal in a lathe is being operated upon by several different tools a number of tool-posts are used, each of which carries its particular tool adjusted to the proper height in the tool-post by means of the screws *c' c'*, and each post is properly positioned lengthwise the block A by the screw *c³*, so that after the first or pattern piece has been finished the several tool-posts, with their properly-adjusted tools, may be quickly inserted in proper succession by the workman for producing duplicate work without the necessity of readjusting the various tools in their posts as each new piece of work is placed in the machine, and by numbering the tool-posts with the tools in proper sequence the workman may make the necessary changes with great rapidity.

In Fig. 4 is shown the tool-post, having an attachment for boring or drilling tools, said attachment consisting of an auxiliary tool-carrier, shown in the present instance as a bar D, pivoted at one end to the tool-post by means of the screw *d* and having a hole *d'* at its other end to receive the tool, the tool-holding end of said bar D being split or cut, as shown, and provided with a clamping-screw *d²* to pinch the tool and hold it in position in the opening or hole *d'*. The bar D may be adjusted by means of the screw *c'* to different heights, and when the desired position has been determined the set-screw *c²* serves to firmly hold and lock the bar A in place.

Having thus described my invention, I claim and desire to protect by Letters Patent—

1. A tool-holder comprising a block or support, a tool-post removably mounted and laterally movable thereon and means for moving said tool-post laterally on said support and locking it in position.

2. A tool-holder comprising a block or support, a tool-post removably mounted and laterally movable thereon, means for adjusting said tool-post lengthwise of said support, and means for moving said tool-post laterally and locking it in position.

3. A tool-holder comprising a block or support, a tool-post removably mounted and laterally movable thereon, means for adjusting the tool in said tool-post, means for securing it in adjusted position, means for adjusting the tool-post and tool lengthwise of said support, and means for moving said tool-post laterally, and locking it in position.

4. A tool-holder comprising a block or support having an undercut abutment, a tool-post having an angular base engaging said undercut abutment removably mounted and laterally movable on said support, and means for moving said tool-post laterally and locking it in position.

5. In a tool-holder, the combination with a block or support having an undercut abutment, of a tool-post removably mounted on said support and provided with an angular base to engage said abutment, and a cam on said support to bear against and lock said tool-post in position.

6. In a tool-holder, the combination with a block or support having an undercut abutment, of a tool-post having an angular or dovetailed base to engage said undercut abutment removably mounted on said support, means for adjusting a tool in said tool-post, means for securing it in adjusted position, and a cam on said support to lock said tool-post in adjusted position.

7. In a tool-holder, the combination with a block or support having an undercut abutment, of a tool-post having an angular or dovetailed base to engage said undercut abutment removably mounted on said support, means for adjusting a tool in said tool-post, means for securing it in adjusted position, means for adjusting said tool-post lengthwise said support, and a cam on said support to lock said tool-post in adjusted position.

8. In a tool-holder, the combination with a block or support having an undercut abutment, of a tool-post having an angular or dovetailed base removably mounted on said support, adjusting-screws carried by said tool-post to adjust the tool to different heights, a set-screw to secure the tool in adjusted position, means carried by the tool-post to secure and maintain an adjustment of said tool-post lengthwise the support, and a cam to lock said tool-post in position.

9. In a tool-holder, the combination with a block or support having an undercut abutment, of a tool-post removably mounted on said support so as to slide freely lengthwise thereof, and having an angular or dovetailed base to engage said undercut abutment, adjusting-screws carried by said tool-post to adjust the tool to different heights, an adjusting-screw tappet in said tool-post and bearing

against the lug or stop on said support to adjust the tool-post lengthwise thereof, and a cam on said support to lock said tool-post in position.

5 10. In a tool-holder, the combination with a block or support, having an undercut abutment, of a tool-post removably mounted and sliding freely thereon, said tool-post having a base with inclined or dovetailed sides one
10 of which engages said undercut abutment; a cam bearing against the other inclined side of said base to lock the tool-post in position, tool-adjusting screws carried by said tool-post, and an adjusting-screw carried by said
15 tool-post and bearing against a lug or stop on the said support to adjust said post lengthwise said support.

11. In a tool-holder, the combination with a block or support, of a tool-post removably
20 mounted and laterally movable thereon, means for adjusting said tool-post lengthwise said support, means for moving said tool-post laterally and locking it in adjusted position, and an auxiliary tool-carrier secured to said
25 tool-post.

12. In a tool-holder, the combination with a block or support, of a tool-post removably mounted therein, means for adjusting said tool-post lengthwise said support, means for
30 locking said tool-post in adjusted position,

and an auxiliary tool-carrier pivoted to said tool-post.

13. In a tool-holder, the combination with a block or support, of a tool-post removably mounted thereon, means for adjusting said
35 tool-post lengthwise said support, means for locking said tool-post in adjusted position, an auxiliary tool-carrier pivoted at one end to said tool-post, means for adjusting said auxiliary carrier to different heights, and
40 means for securing it in adjusted position.

14. In a tool-holder, the combination with a block or support, of a tool-rest removably mounted thereon, an adjusting-screw carried by said tool-post for adjusting said tool-post
45 lengthwise said support, means for locking said tool-post in position, an auxiliary tool-carrier pivoted at one end on said tool-post and provided at its other end with means for holding a tool, an adjusting-screw to adjust
50 the said auxiliary tool-carrier to different heights, and a set-screw to secure the said pivoted carrier in adjusted position.

Signed at Prince's Bay, in the county of Richmond and State of New York, this 18th
55 day of December, A. D., 1899.

LUTHER T. PARSONS.

Witnesses:

FRANK W. HEDDEN,
ANNIE E. HOLBERT.